

# POWERBLOCK®

## HOME RACK STAND ASSEMBLY INSTRUCTIONS

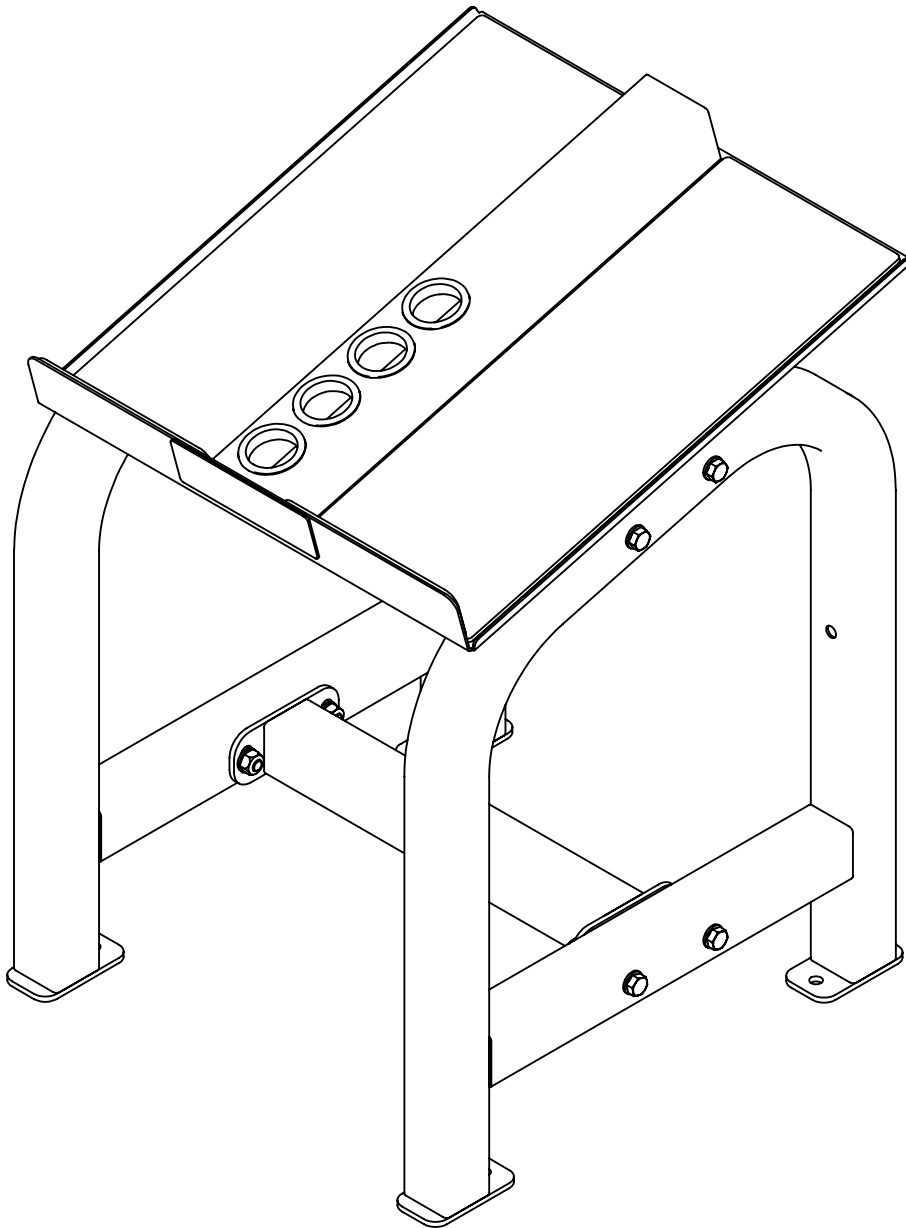





# POWERBLOCK®

## HOME RACK STAND ASSEMBLY STEP 2

ITEM NO.	DESCRIPTION	QTY.
1	LEVELING MOUNTS	4

1. **OPTIONAL:** ATTACH LEVELING MOUNTS (ITEM 1) TO BOTTOM FOOT PLATES AND ADJUST THE HEIGHT OF THE LEVELING MOUNTS BY LOOSENING OR TIGHTENING OF THE THREADS. THEN TIGHTEN THE JAM NUTS.

**FOR USE ON FIRM AND FLAT SURFACE ONLY**

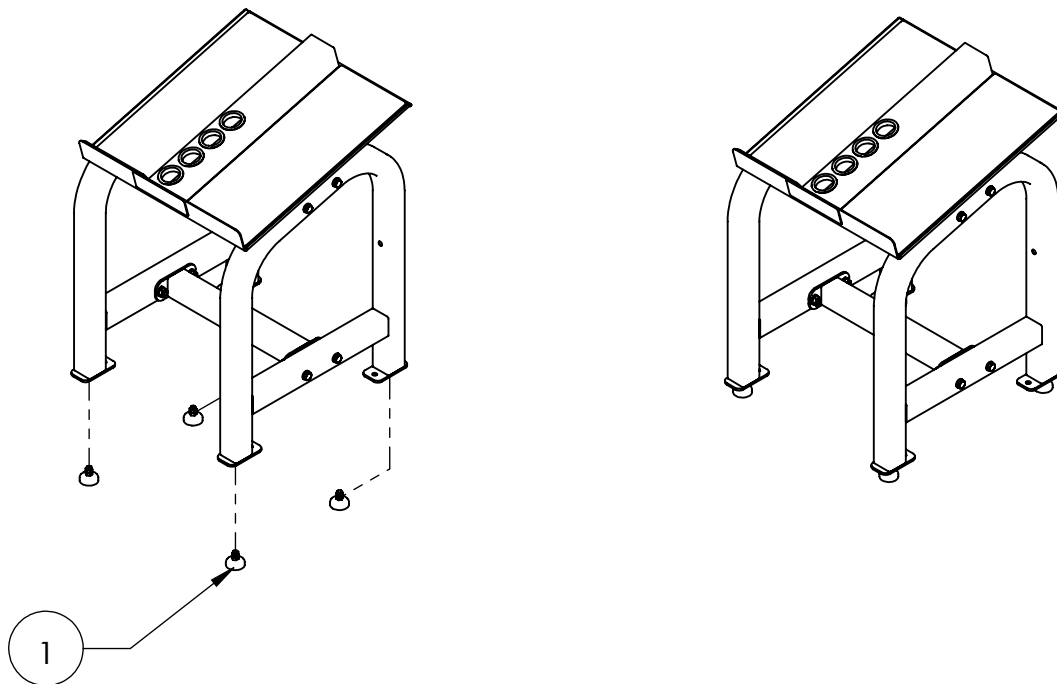

## IMPORTANT SAFETY INSTRUCTIONS

1. Read and fully understand all instructions contained in this manual prior to using the product. Be alerted to the possibility of injury. Do not be careless.
2. Inspect the stand prior to each use. Do not use a stand with worn, damaged, or loose parts, fasteners or hardware.
3. MAX LOAD: 750 lb.
4. Before beginning your workout, make certain that your surroundings are free from potential interference.

 **WARNING:** Injury may occur if stand top tray is not emptied prior to moving the stand. Stand should be moved in a slow and controlled manner.

 **WARNING:** Never allow children to use or play near this equipment. Anyone under the age of 18 must always have parental supervision and instruction on the use of these products.

 **WARNING:** Injury may occur if stand is not assembled per the instruction manual. If you have any questions regarding the assembly, please contact customers service at 1-800-997-3999 .

 **WARNING:** Use the stand on a FLAT AND FIRM SURFACE ONLY. Damage to the products and potential injury may occur.